

JIS B 1180-1994 六角ボルト

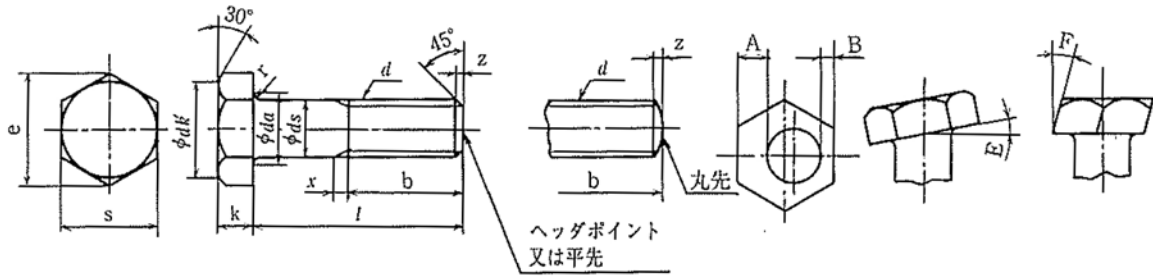

単位:mm

ねじの呼 (d)	M 8	
ピッチ (並)	1.25	
基準寸法	s	13
	k	5.5
	b	22

ねじの呼 (d)	M 10	M 12	(M14)	M 16	M 18	M 20	M 22	M 24	d	
ピッチ (並)	1.5	1.75	2	2	2.5	2.5	2.5	3	P	
基準寸法	s	17	19	22	24	27	30	32	36	s
	k	7	8	9	10	12	13	14	15	k
	b	26	30+(6)	34+(6)	38+(6)	42+(6)	46+(6)	50+(6)	54+(6)	b

首の長さ l (mm)	重量表 (本)	
	重量 (g)	本数
5	7.795	15
6	8.106	16
8	8.728	20
10	9.350	25
12	9.972	30
15	10.91	35
16	11.22	40
20	13.08	45
25	14.27	50
30	16.24	55
35	18.22	60
40	20.19	65
45	22.17	70
50	24.14	75
55	26.12	80
60	28.09	85
65	30.07	90
70	32.02	100
75	34.02	120
80	35.99	140
85	37.97	150
90	39.94	160
95	41.92	180
100	43.89	200
110	47.84	220
120	51.79	240
130	55.74	260
140	59.69	280
150	63.64	300

首の長さ l (mm)	重量表 (本)	
	重量 (g)	本数
15	21.01	15
16	21.51	16
20	23.48	20
25	25.95	25
30	28.90	30
35	31.98	35
40	35.06	40
45	38.14	45
50	41.22	50
55	44.30	55
60	47.38	60
65	50.46	65
70	53.54	70
75	56.62	75
80	59.70	80
85	62.88	85
90	65.86	90
100	72.02	100
120	84.34	120
140	96.66	140
150	102.8	150
160	109.0	160
180	121.3	180
200	133.6	200
220	—	220
240	—	240
260	—	260
280	—	280
300	—	300

六角ボルトは (財) 日本規格協会

ねじ部の重量は b に基き算出したものである。

六角ボルト

JIS
B 1180-1994

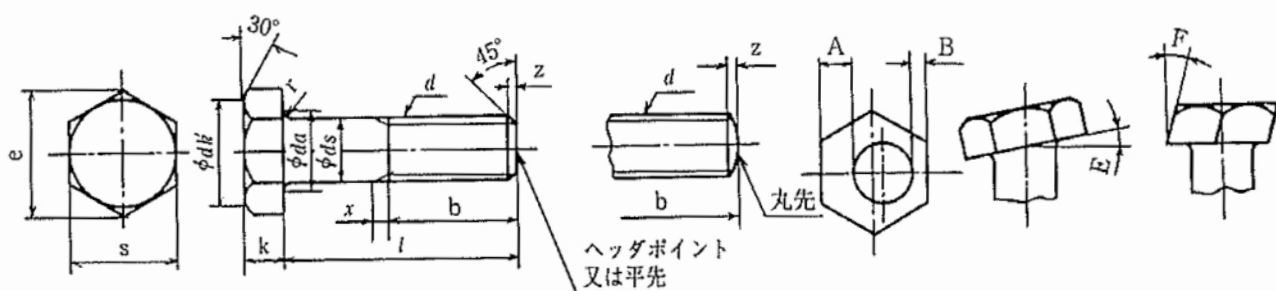

単位:mm

ねじの呼 (d)	M 27	M 30	M 33	M 36	M 39	M 42	M 45	M 48	d	
ピッチ (並)	3	3.5	3.5	4	4	4.5	4.5	5	P	
基準寸法	s	41	46	50	55	60	65	70	75	s
	k	17	19	21	23	25	26	28	30	k
	b	b0+(9)	66+(9)	72+(9)	78+(9)	84+(9)	90+(19)	96+(19)	102+(19)	b
重 量 表 (本) 単位 g										
首の長さ (mm)	30	307.4	412.1	—	—	—	—	—	—	30
	35	326.8	436.0	556.8	—	—	—	—	—	35
	40	346.2	459.8	586.0	743.2	—	—	—	—	40
	45	365.6	483.7	615.3	777.9	—	—	—	—	45
	50	385.0	507.5	644.5	812.5	1013	1211	—	—	50
	55	404.4	531.4	673.8	847.2	1054	1258	1524	1814	55
	60	423.8	555.2	703.0	881.8	1095	1306	1579	1876	60
	65	446.3	579.1	732.3	916.5	1136	1353	1634	1938	65
	70	468.8	606.1	761.5	951.1	1177	1401	1689	2001	70
	75	491.2	633.8	793.3	985.8	1219	1448	1744	2063	75
	80	513.7	661.6	826.9	1022	1260	1496	1799	2125	80
	85	536.2	689.3	860.5	1062	1302	1543	1854	2187	85
	90	558.7	717.1	894.1	1102	1349	1591	1909	2249	90
	100	603.6	772.6	961.2	1182	1443	1700	2025	2373	100
	120	693.5	883.5	1096	1342	1630	1918	2275	2654	120
	140	783.4	994.5	1230	1502	1818	2135	2524	2938	140
	150	828.4	1050	1297	1582	1911	2244	2649	3080	150
	160	873.3	1105	1364	1662	2005	2352	2774	3222	160
	180	963.2	1217	1498	1822	2193	2570	3024	3506	180
	200	1053	1328	1633	1981	2381	2787	3273	3790	200
220	1143	1438	1767	2142	2568	3005	3523	4074	220	
240	1233	1549	1901	2301	2756	3222	3773	4358	240	
260	1323	1661	2035	2461	2944	3440	4023	4642	260	
280	1413	1771	2170	2621	3131	3657	4272	4926	280	
300	1323	1882	2304	2780	3319	3875	4522	5211	300	
325	1615	2021	2472	2980	3553	4147	4834	5566	325	
350	1728	2160	2639	3179	3788	4419	5146	5921	350	
375	1840	2299	2807	3340	4022	4691	5458	6276	375	
400	1952	2437	2975	3580	4256	4963	5458	6631	400	

JIS

B 1180-1994

六角ボルト

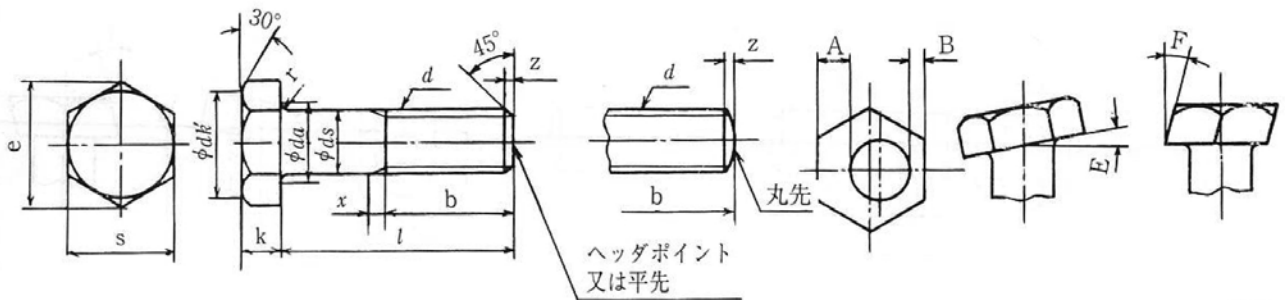

単位mm

ねじの呼 (d)	M 52	M 56	M 60	M 64	M 68	M 72	M 76	M 80	d	
ピッチ (並)	5	5.5	5.5	6	6	細目 6	細目 6	細目 6	P	
基準寸法	s	80	85	90	95	100	105	110	115	s
	k	33	35	38	40	43	45	48	50	k
	b	116+(13)	124+(13)	132+(13)	140+(13)	148+(13)	156+(13)	164+(13)	172+(13)	b
重量表 (本)										
		単位kg								
首 下 の 長 さ l (%)	60	2.300	—	—	—	—	—	—	—	60
	65	2.374	2.805	—	—	—	—	—	—	65
	70	2.447	2.890	3.449	—	—	—	—	—	70
	75	2.521	2.976	3.547	4.106	—	—	—	—	75
	80	2.595	3.061	3.646	4.219	4.926	—	—	—	80
	85	2.668	3.146	3.745	4.331	5.054	5.778	—	—	85
	90	2.742	3.232	3.844	4.443	5.181	5.922	6.803	7.676	90
	95	2.816	3.317	3.943	4.555	5.309	6.066	6.964	7.855	95
	100	2.889	3.402	4.041	4.667	5.436	6.209	7.125	8.034	100
	120	3.192	3.744	4.437	5.116	5.946	6.785	7.770	8.752	120
	140	3.525	4.121	4.852	5.565	6.456	7.360	8.415	9.470	140
	150	3.692	4.315	5.074	5.818	6.717	7.648	8.737	9.829	150
	160	3.858	4.508	5.296	6.070	7.002	7.950	9.059	10.19	160
	180	4.192	4.895	5.739	6.575	7.572	8.588	9.758	10.93	180
	200	4.525	5.282	6.183	7.080	8.143	9.227	10.47	11.72	200
	220	4.859	5.668	6.627	7.585	8.713	9.867	11.18	12.52	220
	240	5.192	6.055	7.071	8.090	9.283	10.51	11.90	13.30	240
	260	5.526	6.442	7.515	8.595	9.853	11.15	12.61	14.09	260
	280	5.859	6.828	7.959	9.100	10.42	11.78	13.32	14.88	280
	300	6.192	7.215	8.403	9.605	10.99	12.42	14.03	15.67	300
325	6.609	7.699	8.956	10.24	11.71	13.22	14.92	16.66	325	
350	7.026	8.182	9.513	10.87	12.42	14.02	15.81	17.64	350	
375	7.443	8.665	10.07	11.50	13.13	14.82	16.70	18.63	375	
400	7.860	9.149	10.62	12.13	13.85	15.62	17.59	19.61	400	
425	8.276	9.632	11.18	12.76	14.56	16.42	18.48	20.60	425	
450	8.693	10.116	11.73	13.40	15.27	17.22	19.37	21.59	450	
475	9.110	10.599	12.29	14.03	15.98	18.02	20.26	22.58	475	
500	9.527	11.082	12.84	14.66	16.70	18.82	21.15	23.56	500	
600	11.194	13.016	15.06	17.18	19.55	22.01	24.72	27.51	600	

本表は(本)kgで表示してある。